

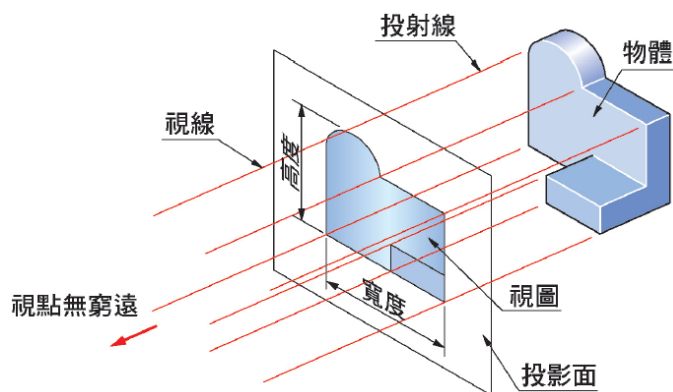

# 正 投 影

## 3 章

### 本章節次



3-1 投影法與投影圖之種類

3-2 第一角與第三角投影

3-3 點、線、面、體之投影

3-4 視圖線條之意義

3-5 視圖之選擇與排列

3-6 線條之優先順序

3-7 正投影視圖畫法

3-8 識圖與製圖練習

# 投影現象實例

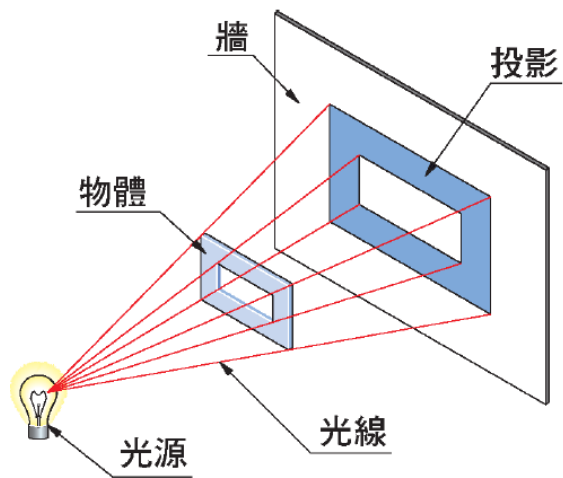

(a) 光源

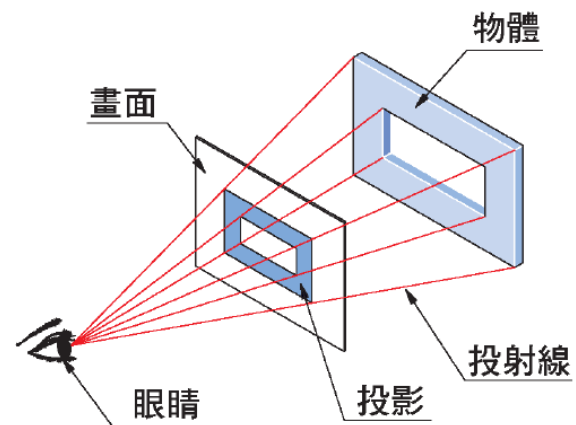

(b) 眼睛

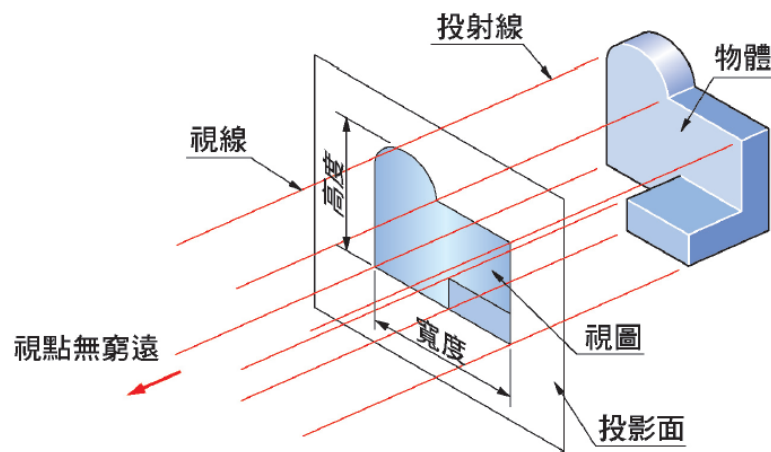

↑ 正投影原理

# 投影箱的展開

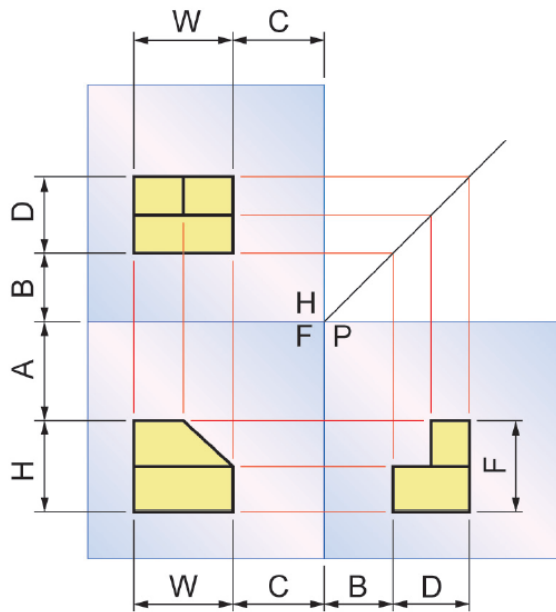
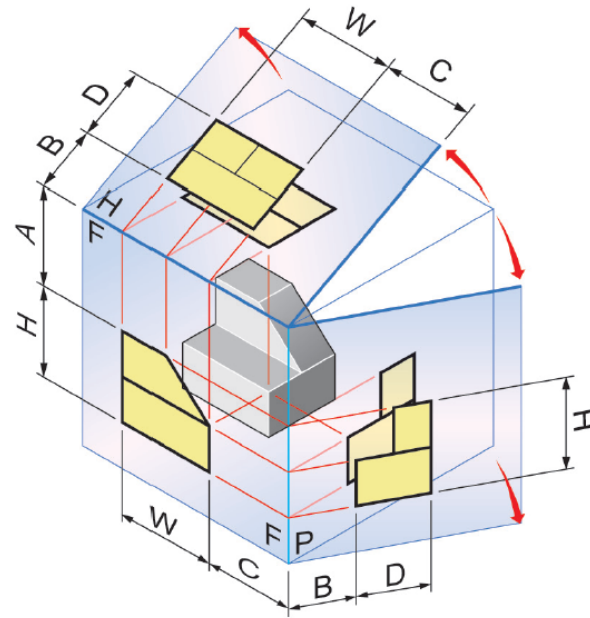
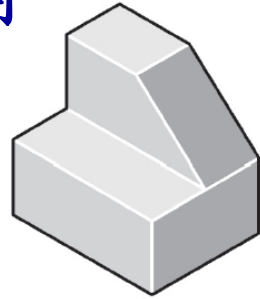

↑ 投影箱展開圖



搜尋

瀏覽

上傳

## 8透視圖學1

a5254805

32 部影片

訂閱

**透視圖學的定義**

透視圖學是由Perspective翻譯而來，含有明察秋毫，穎悟敏銳的意義，有觀察探討，圖形的意思。

透視圖學並不是透過某一個視點去窺視其內部，亦不是醫療上的x光透視，透視圖學是透過繪畫的畫面去理解物體後面各部份的空間位置，因此透視圖學也是探討物體空間關係的學問。

透視圖學是研究物體如何呈現在畫面上，使其遠近、大小與正常習慣視覺所見的狀況相似的一種科學。

1:09 / 8:04

↑ 透視圖學1

## 三個主要投影面：

1. 直立投影面

2. 水平投影面

3. 側投影面

## 空間中的四個象限

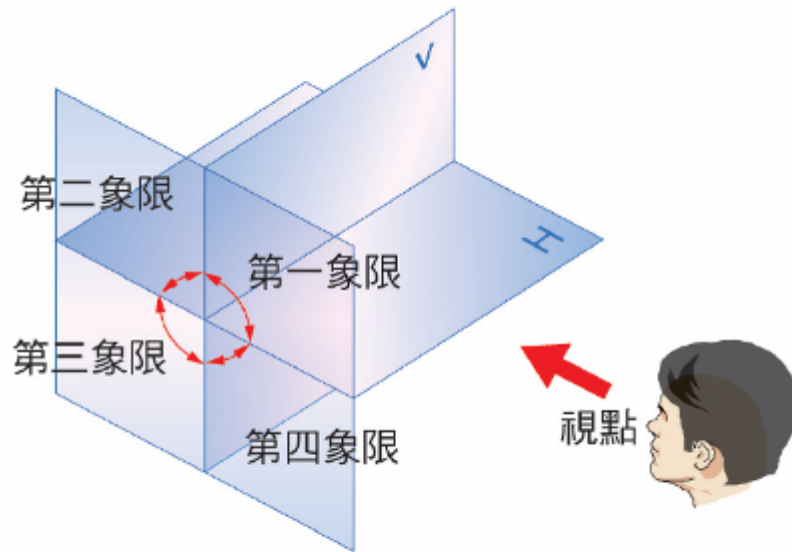

(a)空間中的四個象限

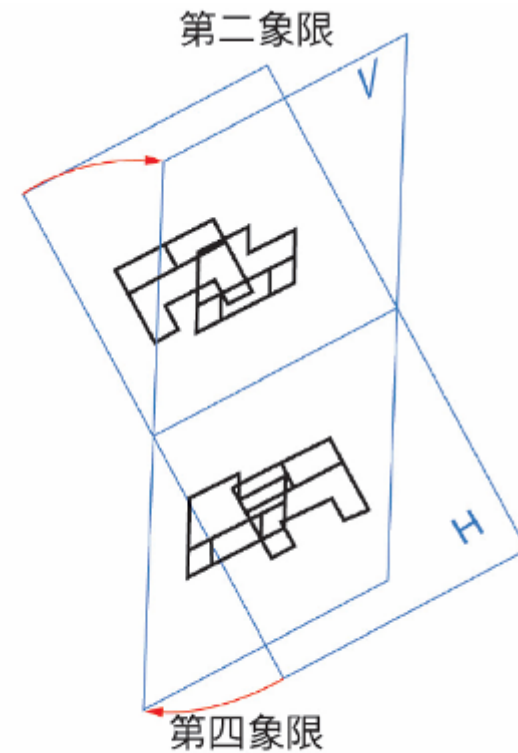

(b)第二角投影及第四角投影的結果



搜尋

瀏覽

上傳

## 投影箱教學

a5254805

32 部影片

訂閱

投影箱教學影片

0:02 / 2:56

360p

 投影箱教學

# 第一角投影

投影順序：觀察者 → 物體 → 投影面

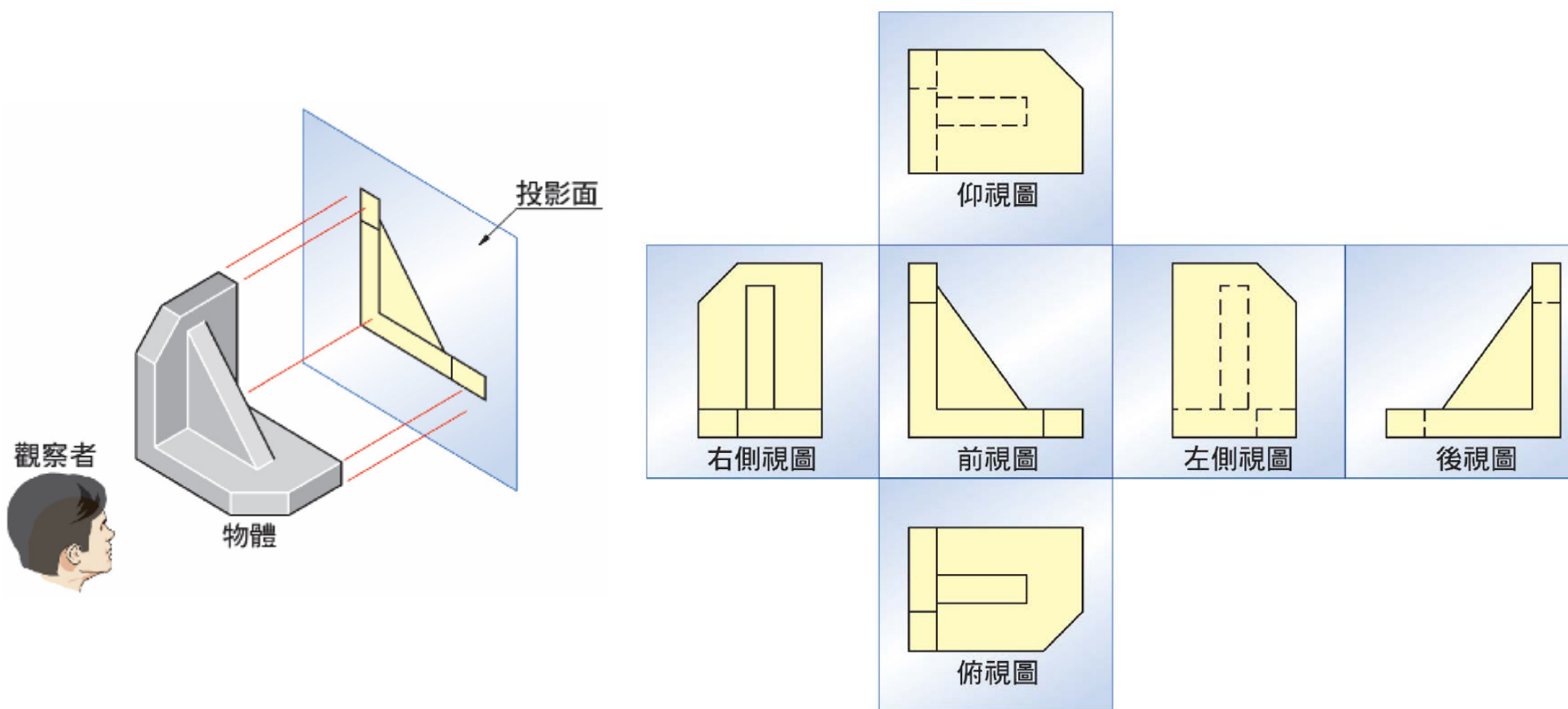

↑ 第一角投影

# 第三角投影

投影順序：觀察者 → 投影面 → 物體

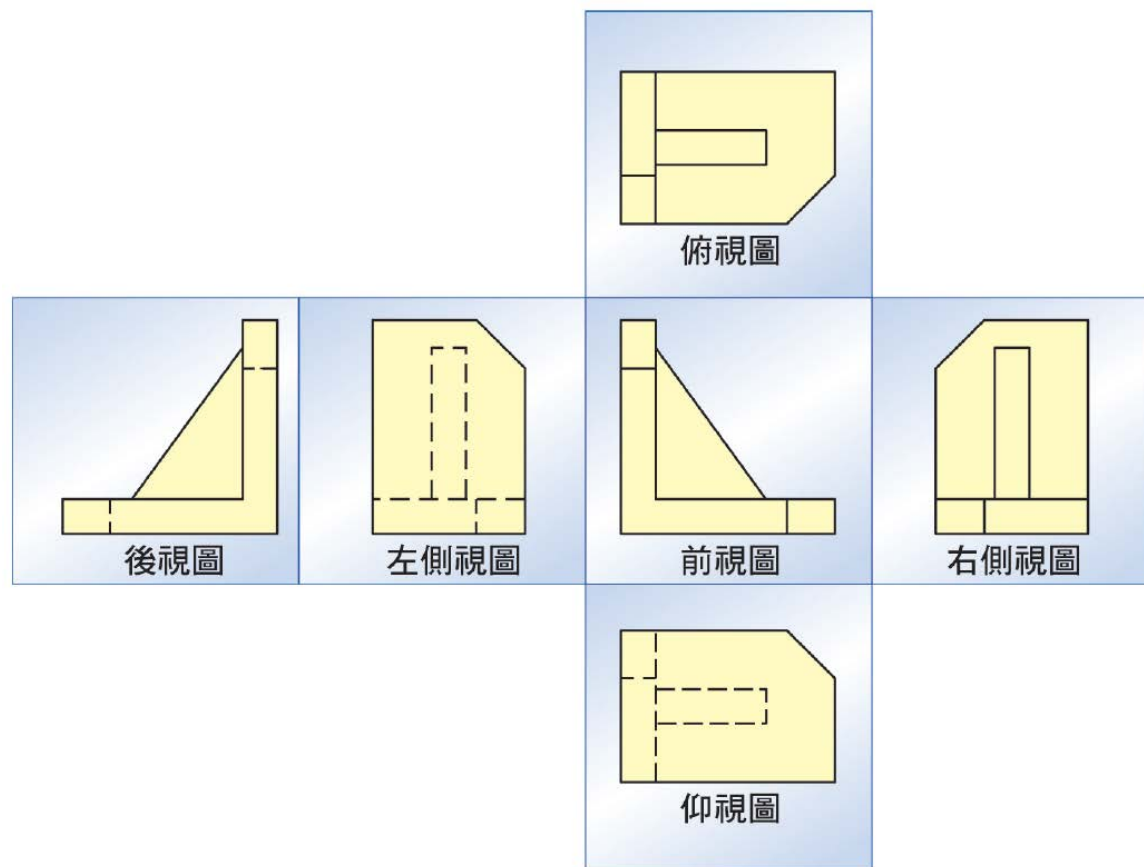
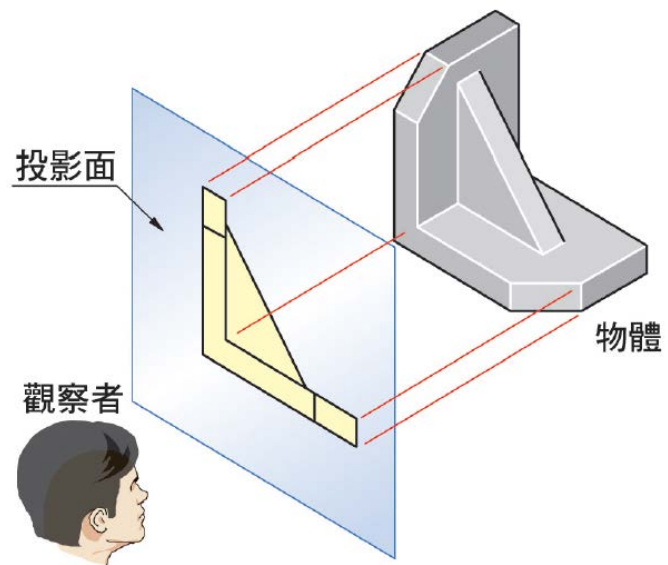

↑ 第三角投影

# 投影符號

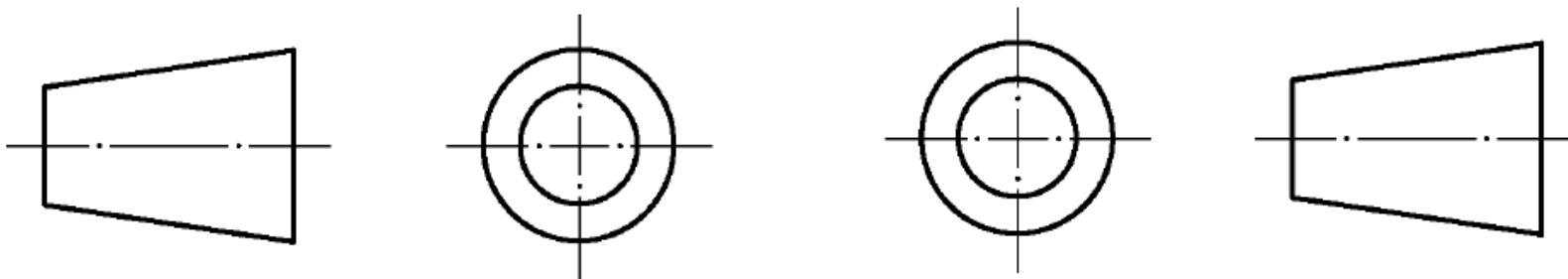

(a) 第一角投影

(b) 第三角投影

↑ 投影符號

# 點之投影

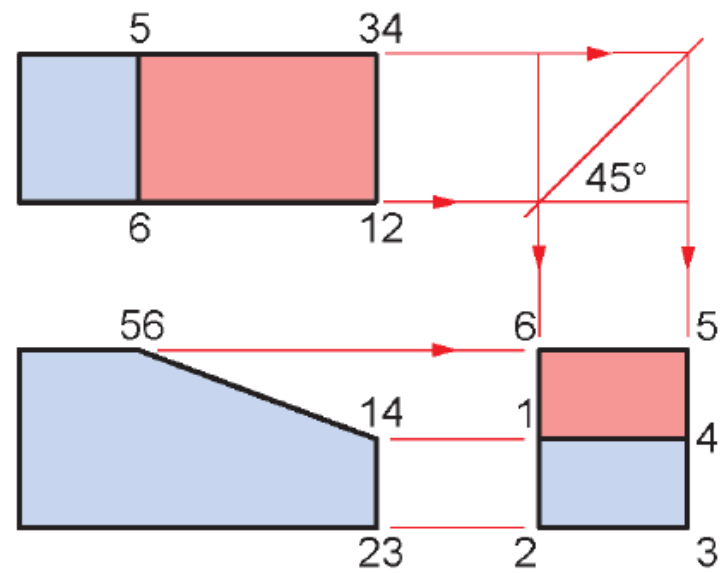
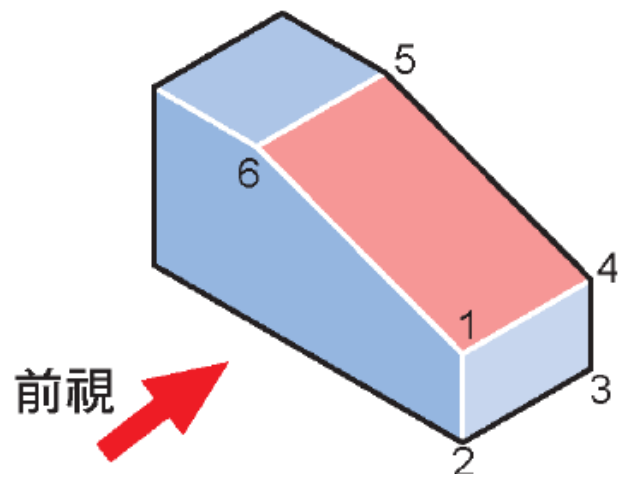

↑ 點的投影

# 線之投影

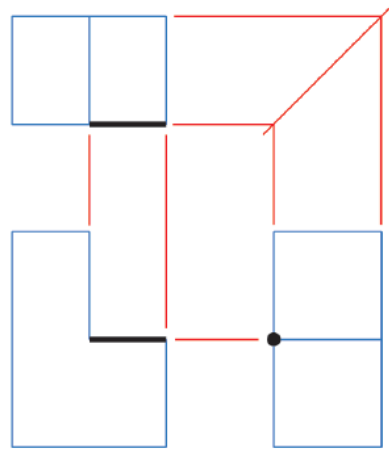
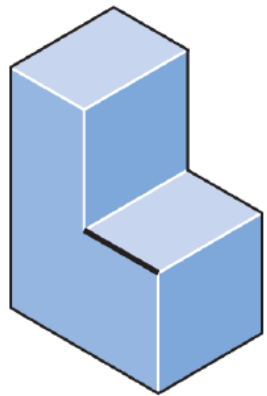

↑ 正垂線在三個視圖上之應用

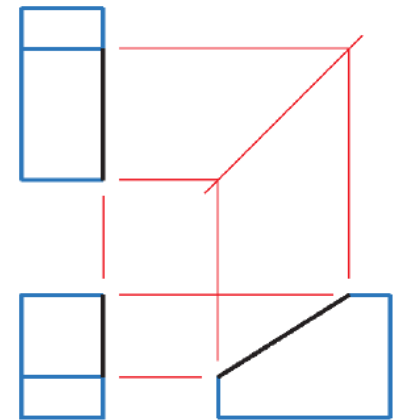
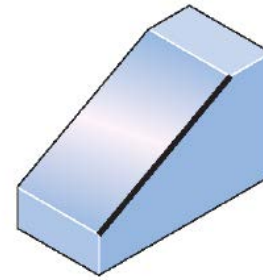

↑ 單斜線在三個視圖上之應用

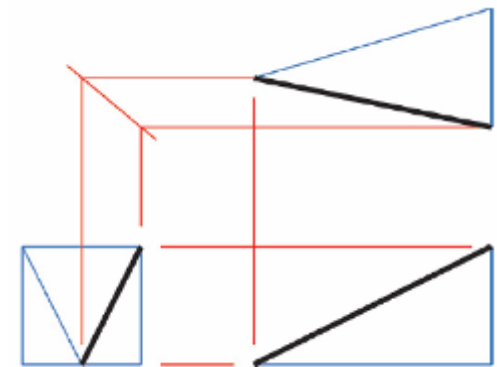
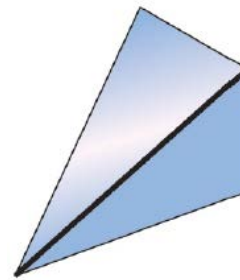

↑ 複斜線在三個視圖上之應用

# 面之投影

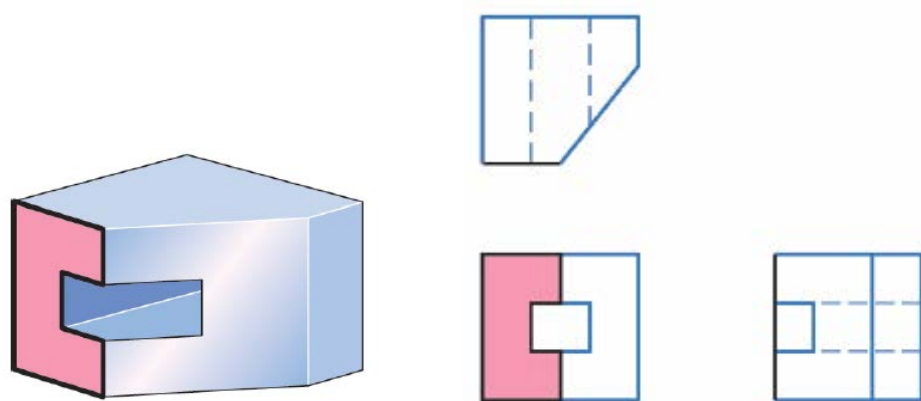

↑ 正垂面在三個視圖上之應用

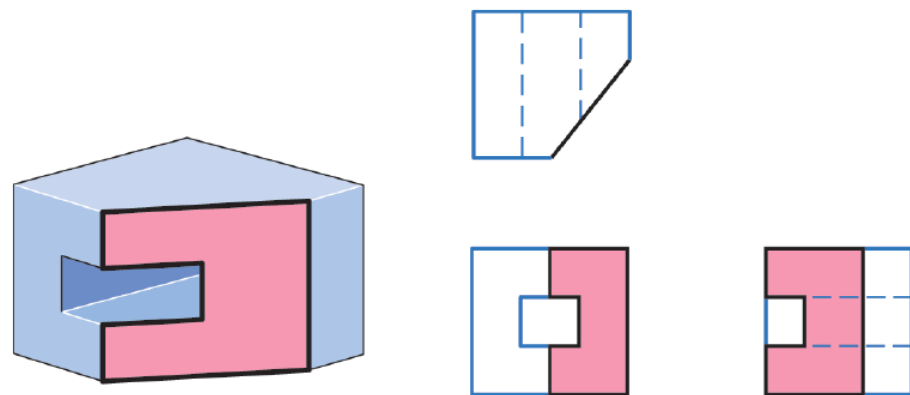

↑ 單斜面在三個視圖上之應用

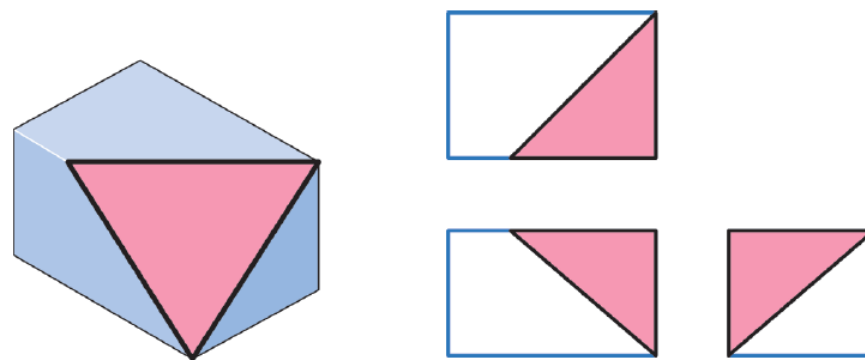

↑ 複斜面在三個視圖上之應用

# 體之投影

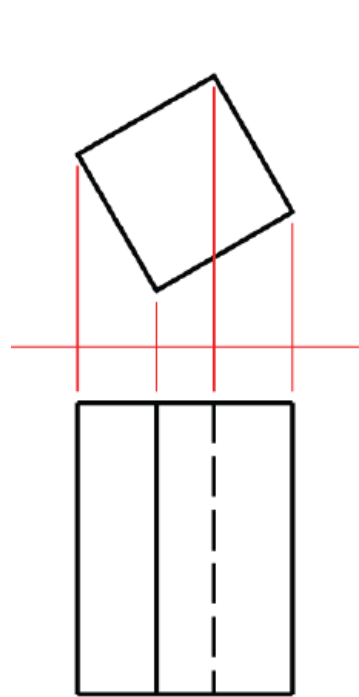

(a) 方柱

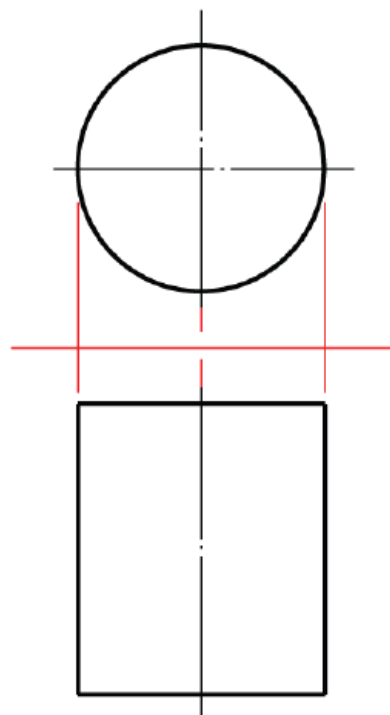

(b) 圓柱

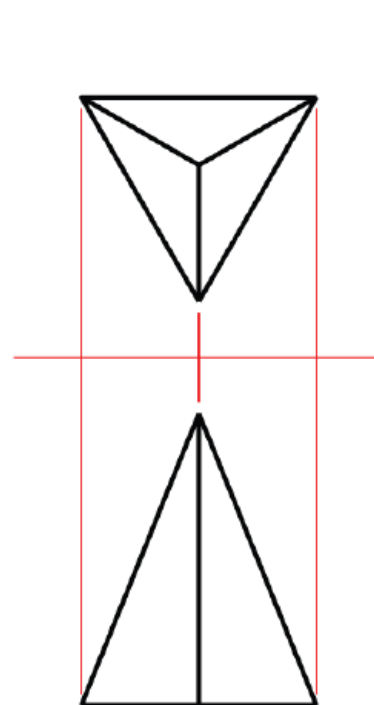

(c) 三角錐

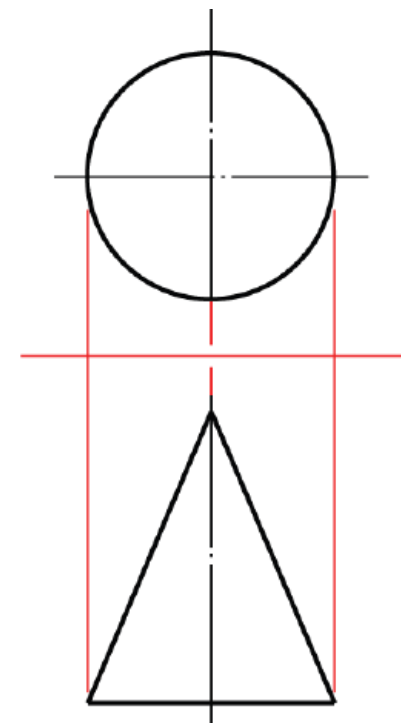

(d) 圓錐

↑ 直立體之投影

## 線條之意義：

1. 平面的邊視圖

2. 面的交線

3. 曲面的極限

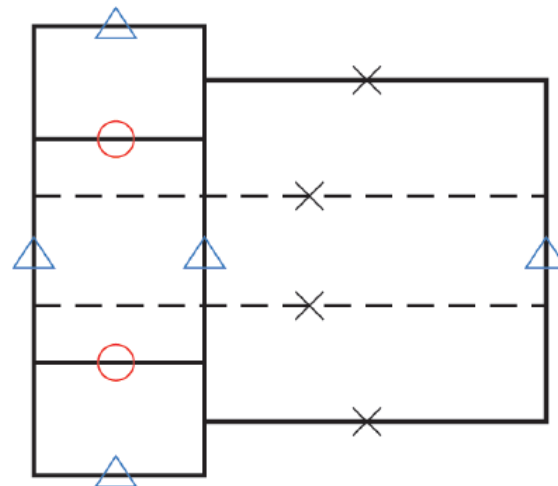
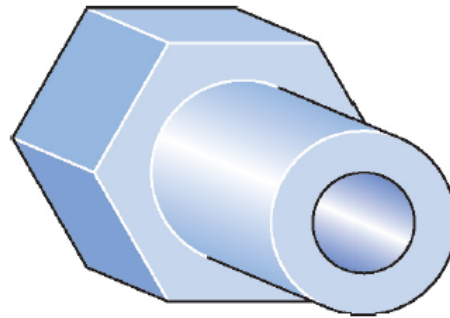

- △ 平面的邊視圖
- 面的交線
- × 曲面的極限

↑ 線條的意義

# 物體的放置

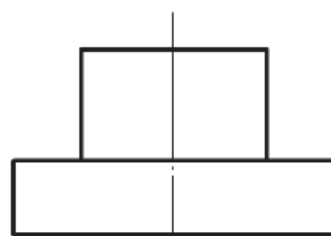
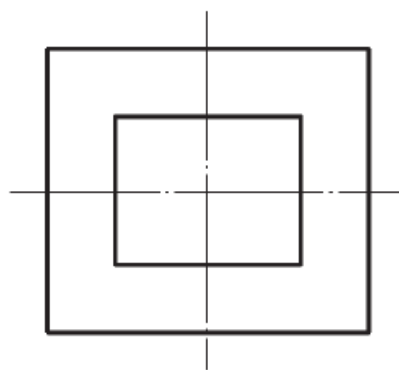
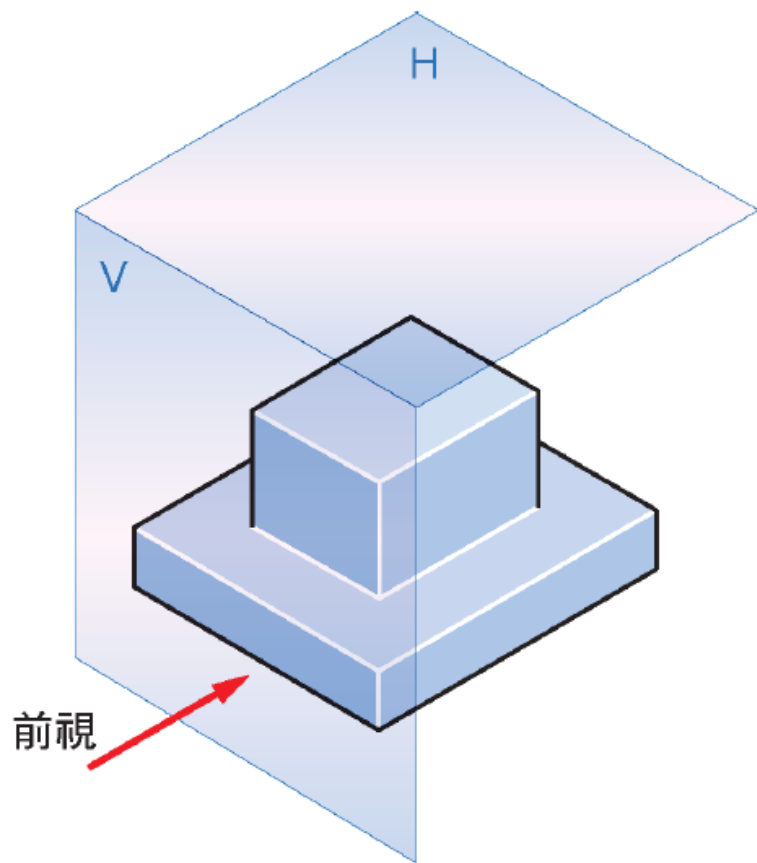

正確

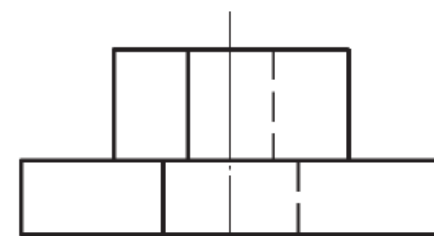
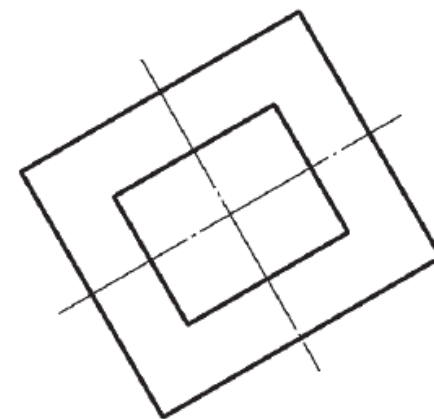

錯誤

↑ 物體的放置

# 前視圖的選擇

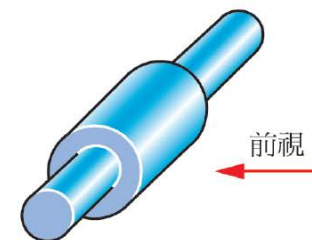
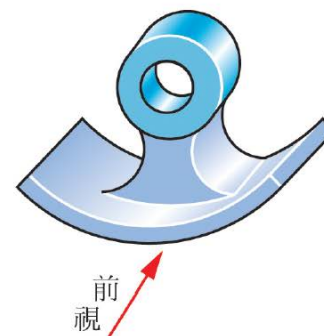
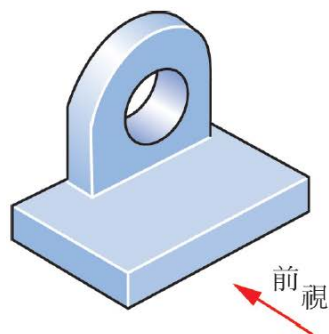
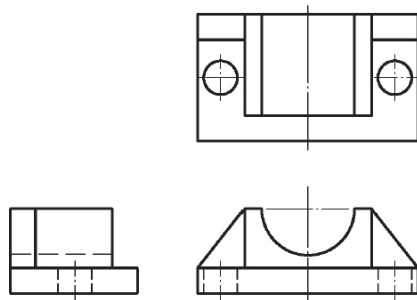
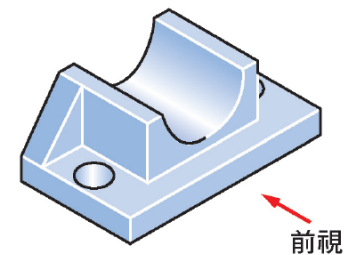
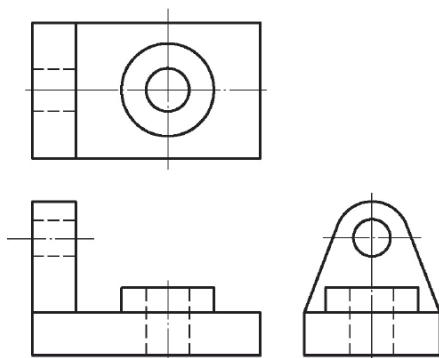
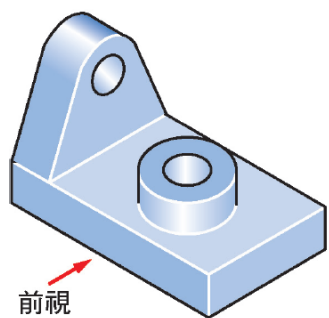

↑ 前視圖的選擇

↑ 物體的放置

## 視圖數量的確定

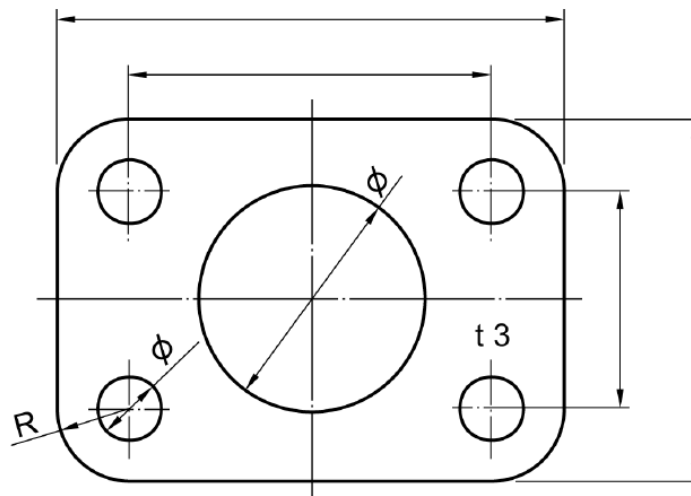
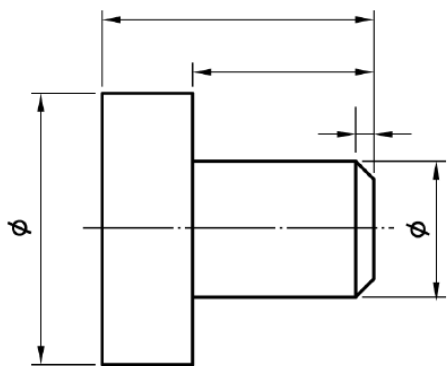

↑ 使用一個視圖

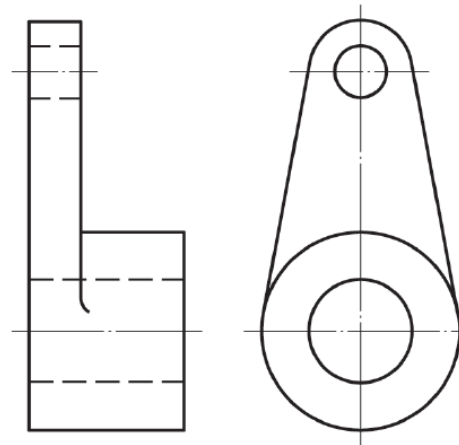
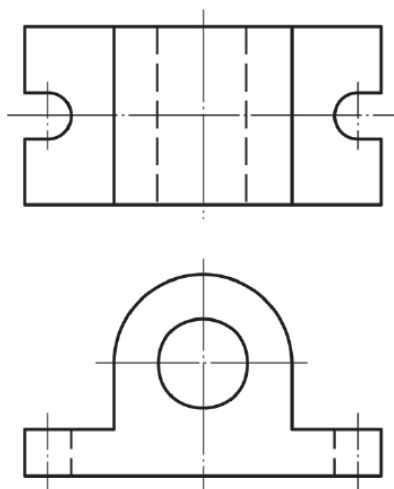

↑ 使用兩個視圖

# 視圖的排列

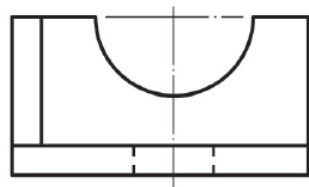
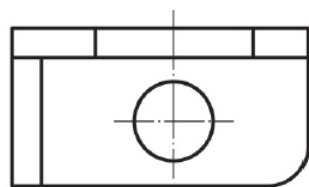
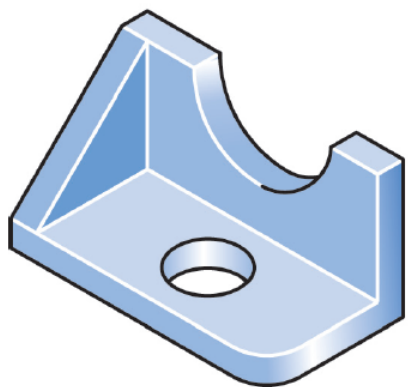

正確

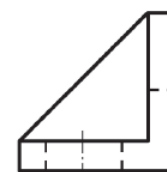
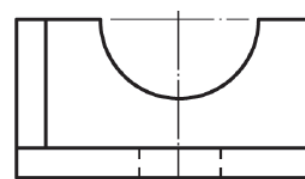
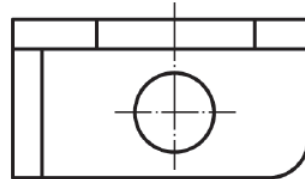
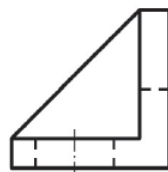

錯誤

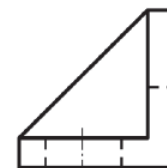
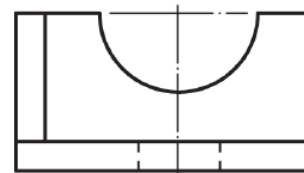
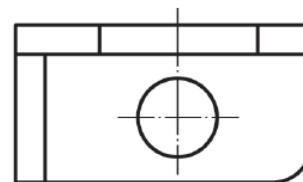

錯誤

↑ 視圖的排列

## 線條重疊時的優先次序

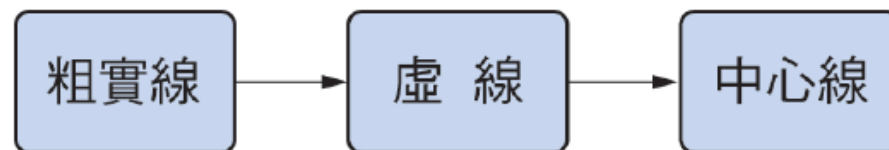

↑ 線條的優先順序

虛線與中心線重合畫虛線

粗實線與虛線重合畫粗實線

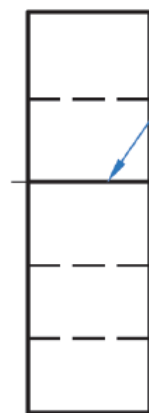
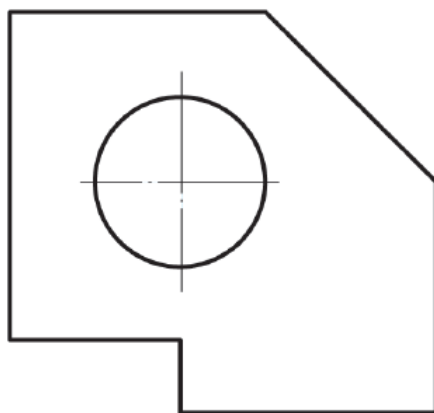
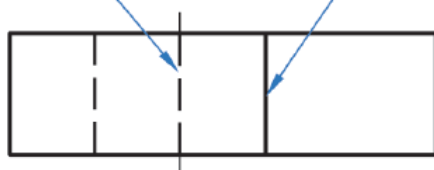

粗實線與中心線重合畫粗實線

↑ 線條優先順序之圖示

## 繪製平面圖的步驟

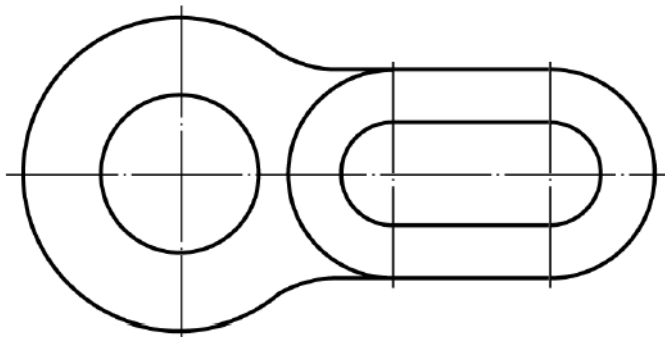

(a) 平面圖

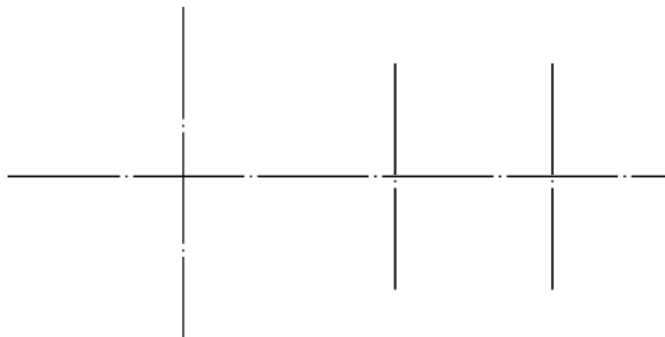

(b) 繪製中心線

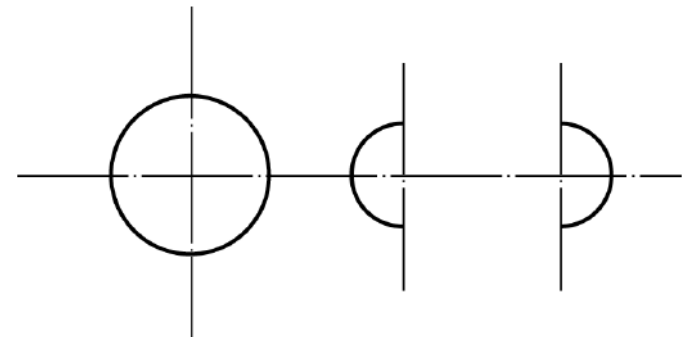

(c) 繪製小圓

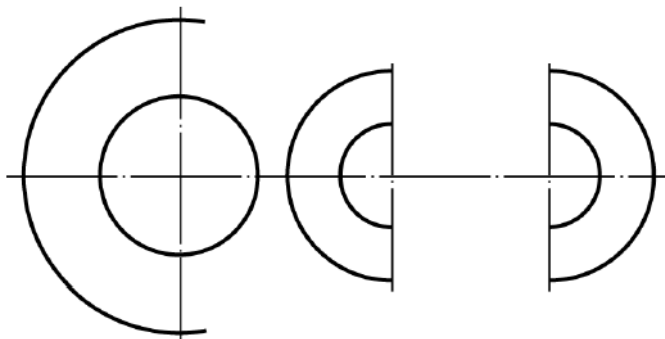

(d) 繪製大圓

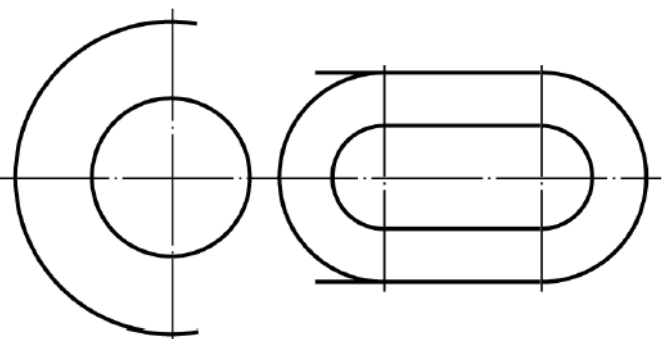

(e) 繪製直線

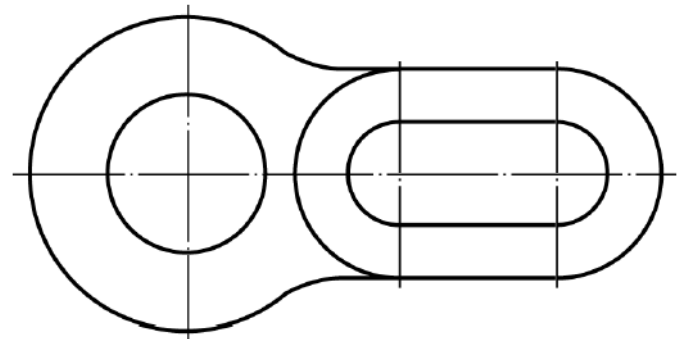

(f) 完成平面圖

# 繪製正投影視圖的步驟

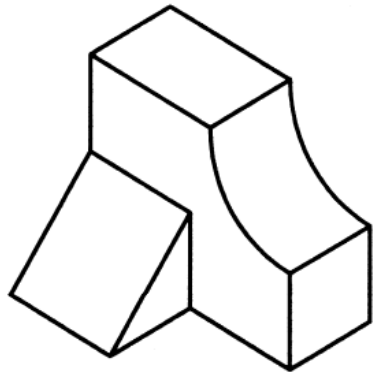

(a) 立體圖

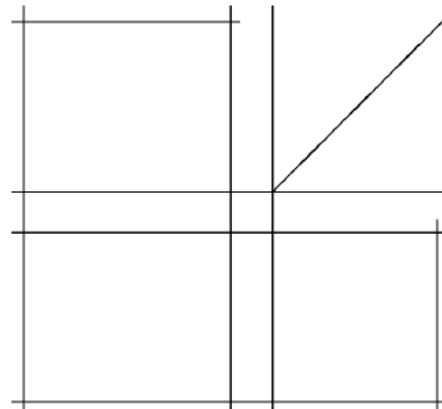

(b) 繪製起草方格

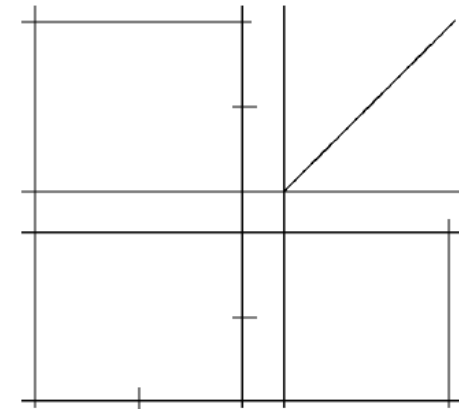

(c) 作出輪廓記號

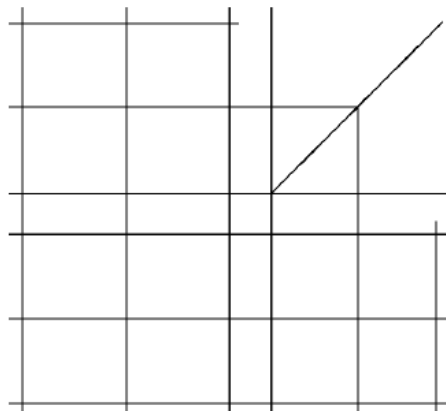

(d) 繪出基本架構

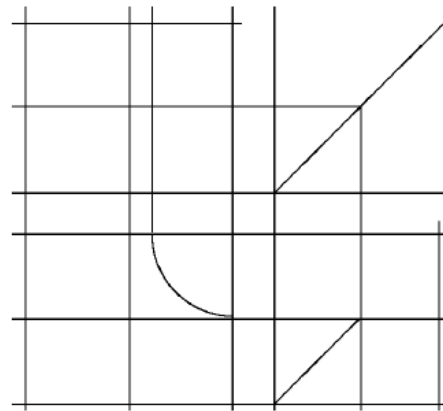

(e) 繪出斜面及圓弧

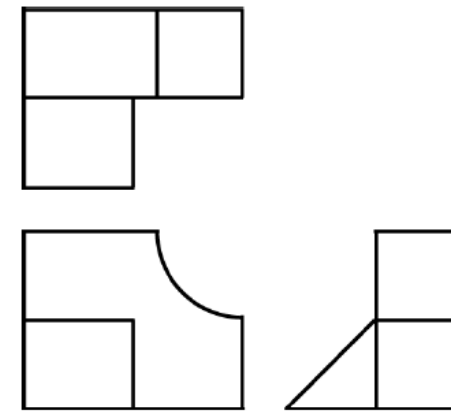

(f) 描繪完成之三個視圖

↑ 正投影視圖繪製

# 直接讀圖法

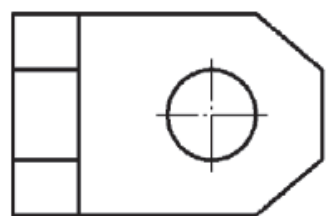

俯視圖

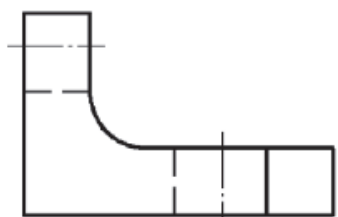

前視圖

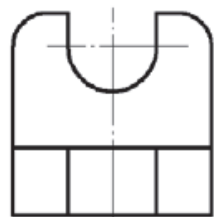

右側視圖

(a) 三個視圖

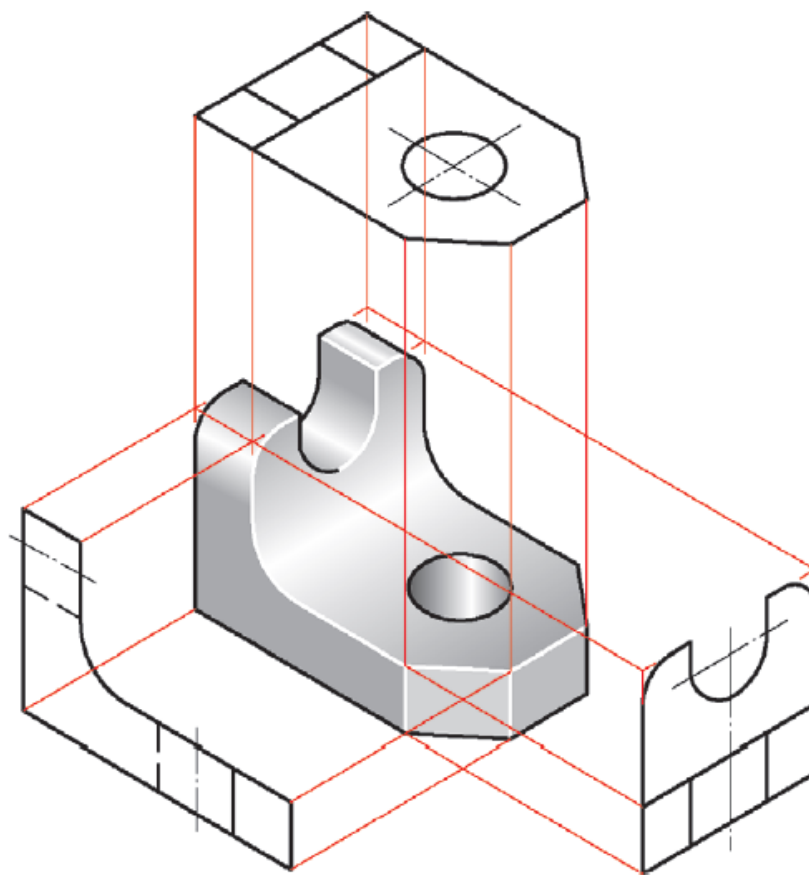

(b) 直接讀圖法

# 模型輔助法

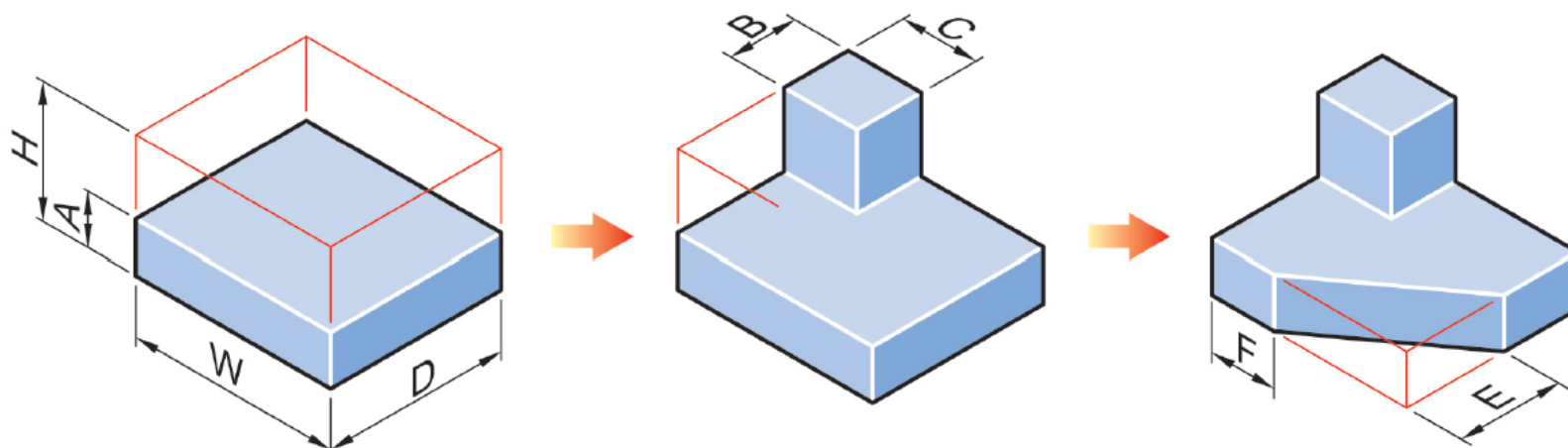
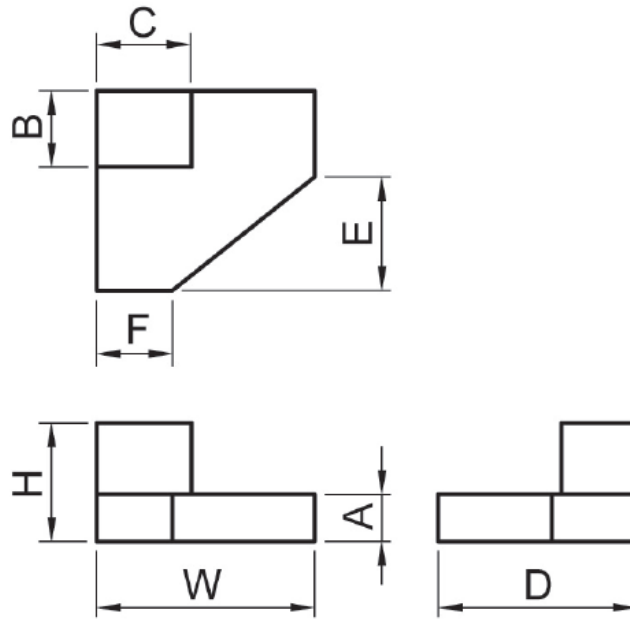

↑ 模型輔助法

# 立體草圖繪製法

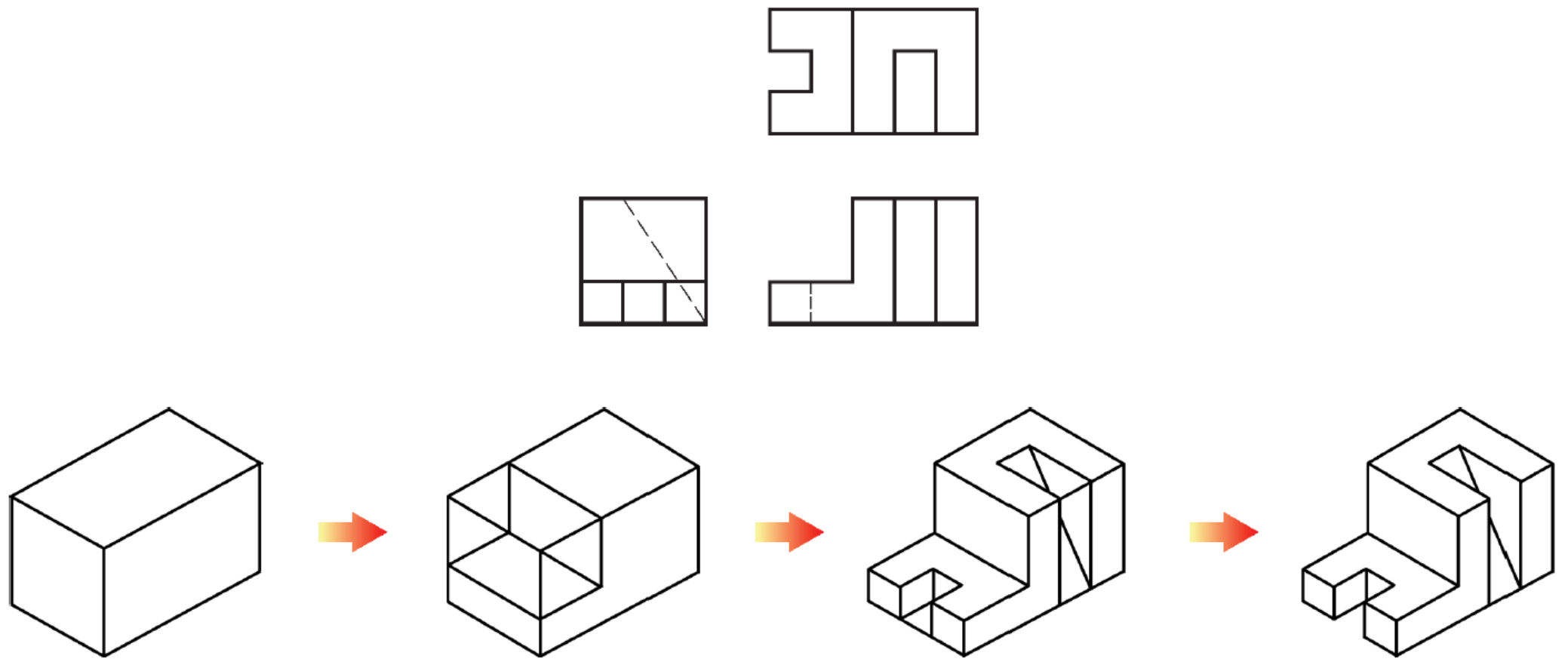

↑ 立體草圖繪製法

# 識圖練習

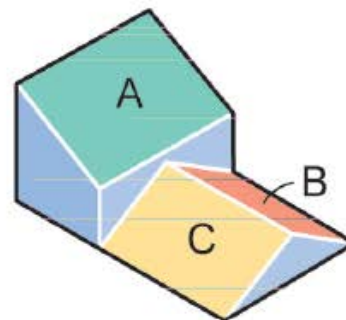
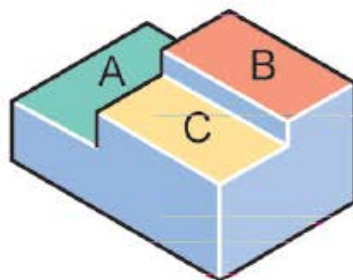
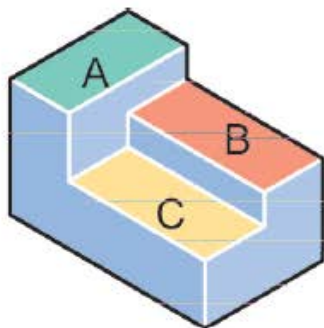
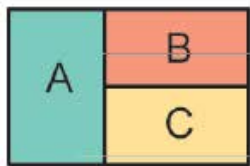

↑ 由單一視圖判讀之情形

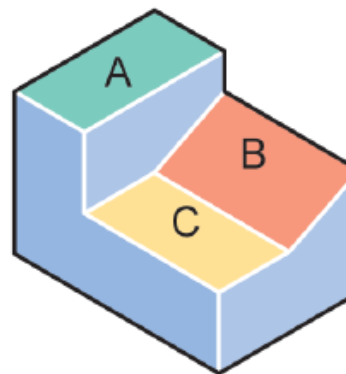
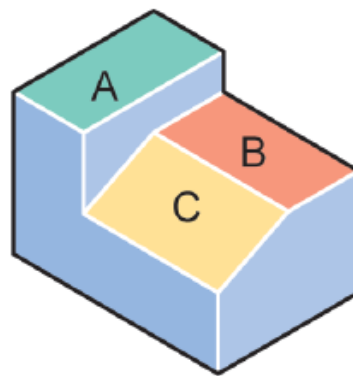
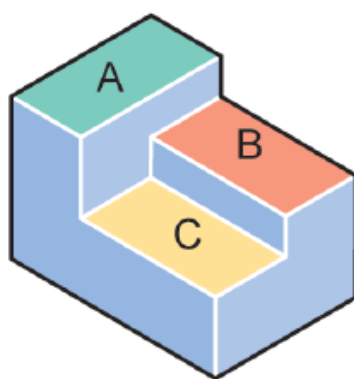
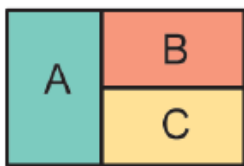

↑ 由兩個視圖判讀之情形

# 識圖練習

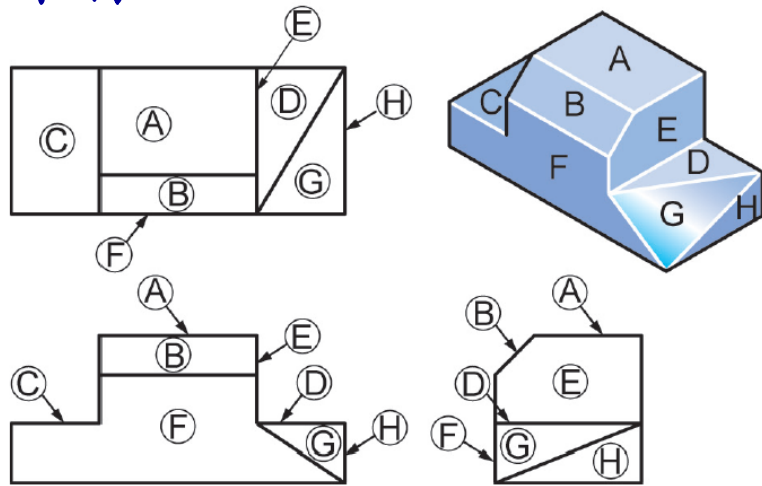

種類 \ 視圖	前視圖	俯視圖	右側視圖
邊視圖	ACDEH	EFH	ABCDF
正垂面	F	ACD	EH
單斜面	B	B	
複斜面	G	G	G

範例

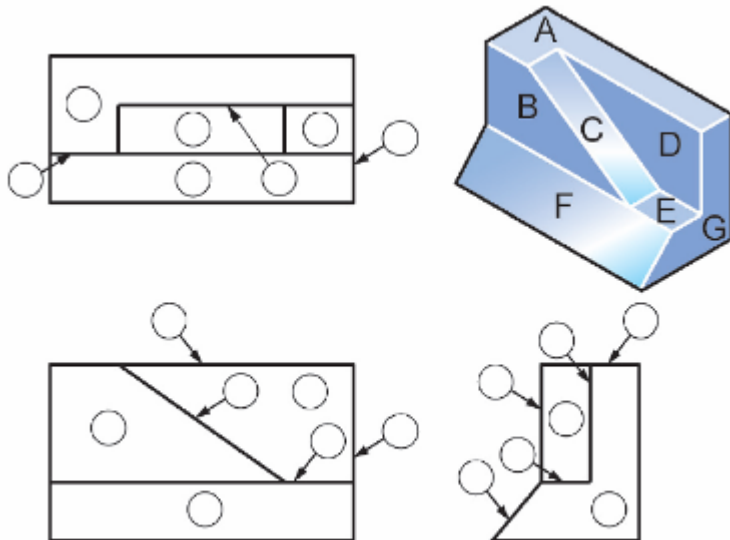

種類 \ 視圖	前視圖	俯視圖	右側視圖
邊視圖			
正垂面			
單斜面			
複斜面			

(a) 練習一

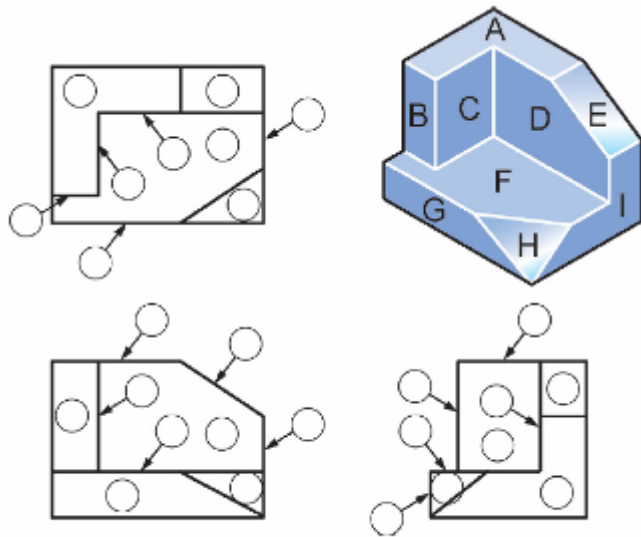

種類 \ 視圖	前視圖	俯視圖	右側視圖
邊視圖			
正垂面			
單斜面			
複斜面			

(b) 練習二

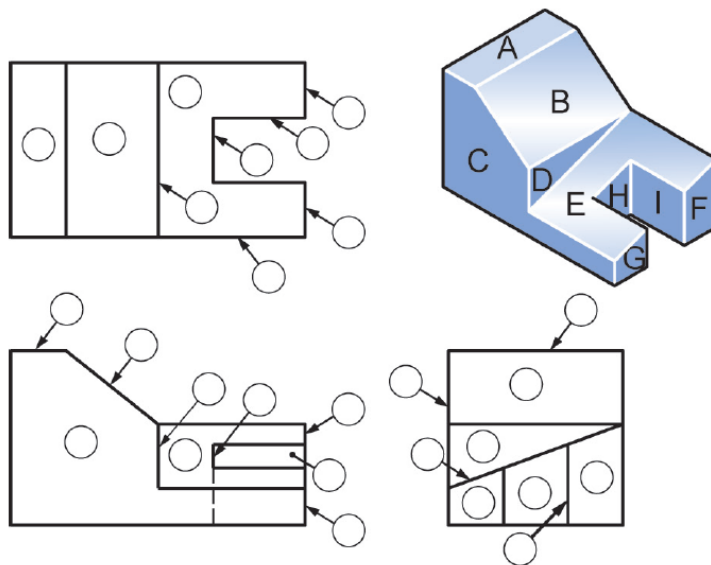

種類 \ 視圖	前視圖	俯視圖	右側視圖
邊視圖			
正垂面			
單斜面			
複斜面			

(c) 練習三

# 補線練習

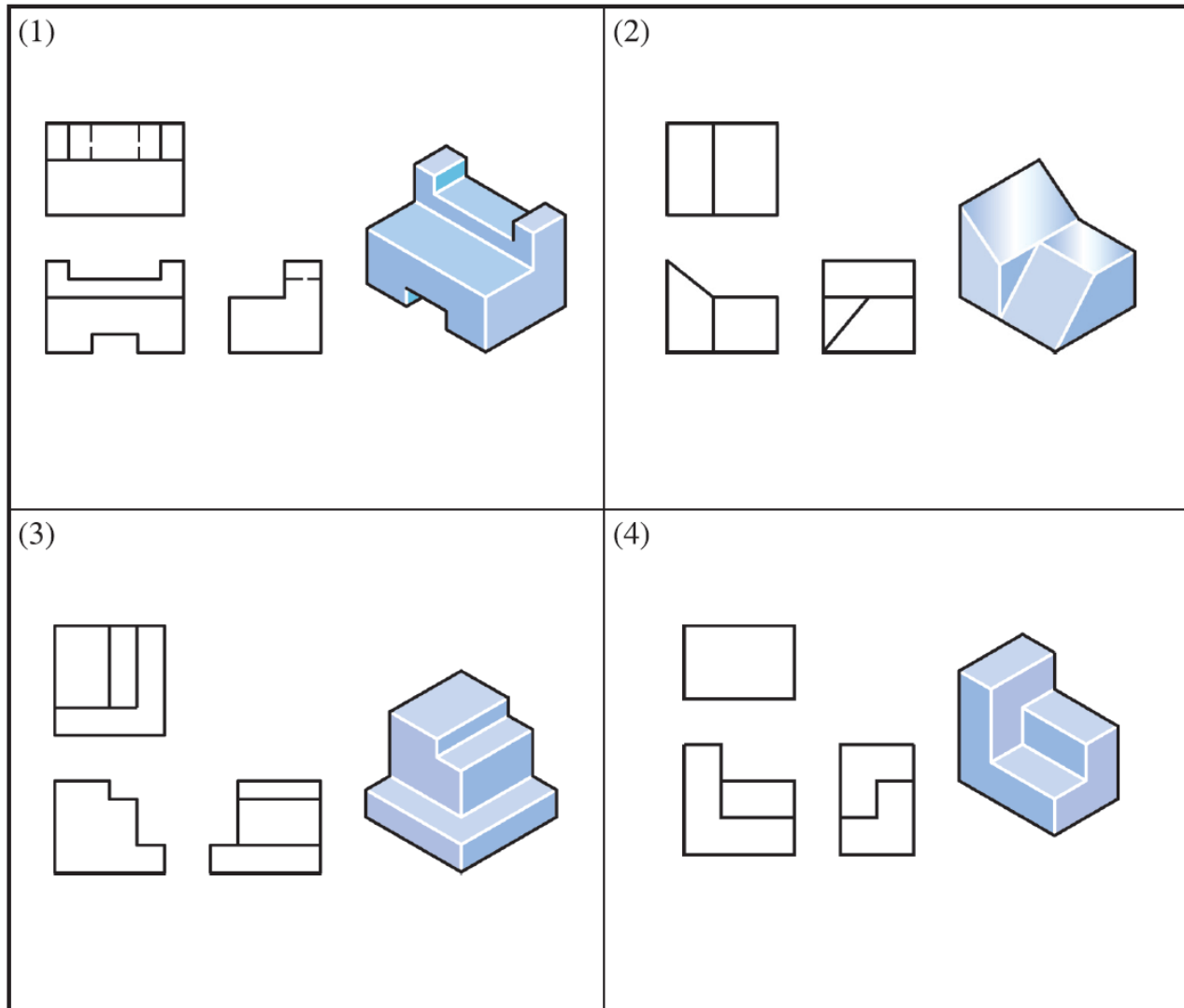

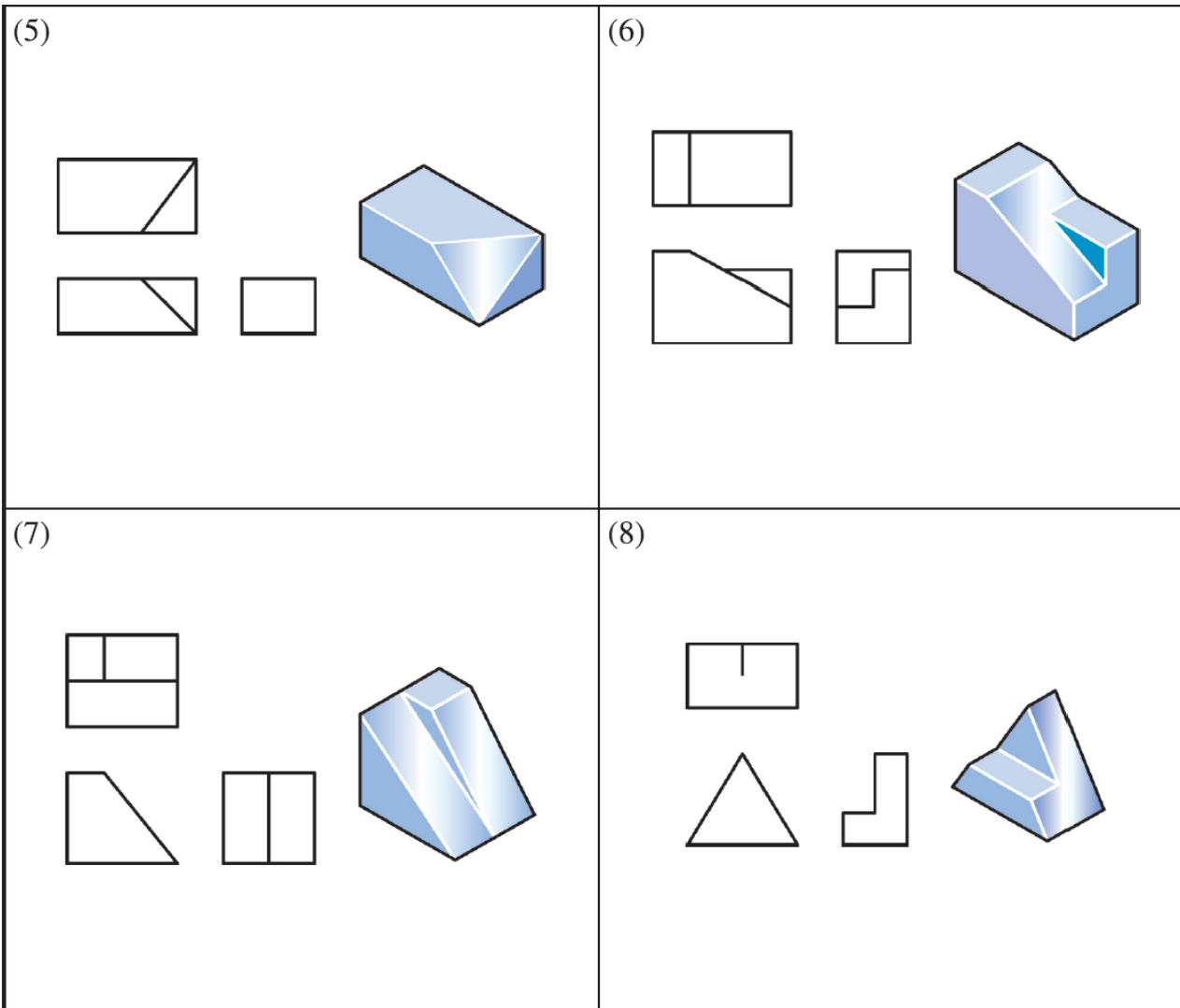

↑ 補線練習(一)(續)

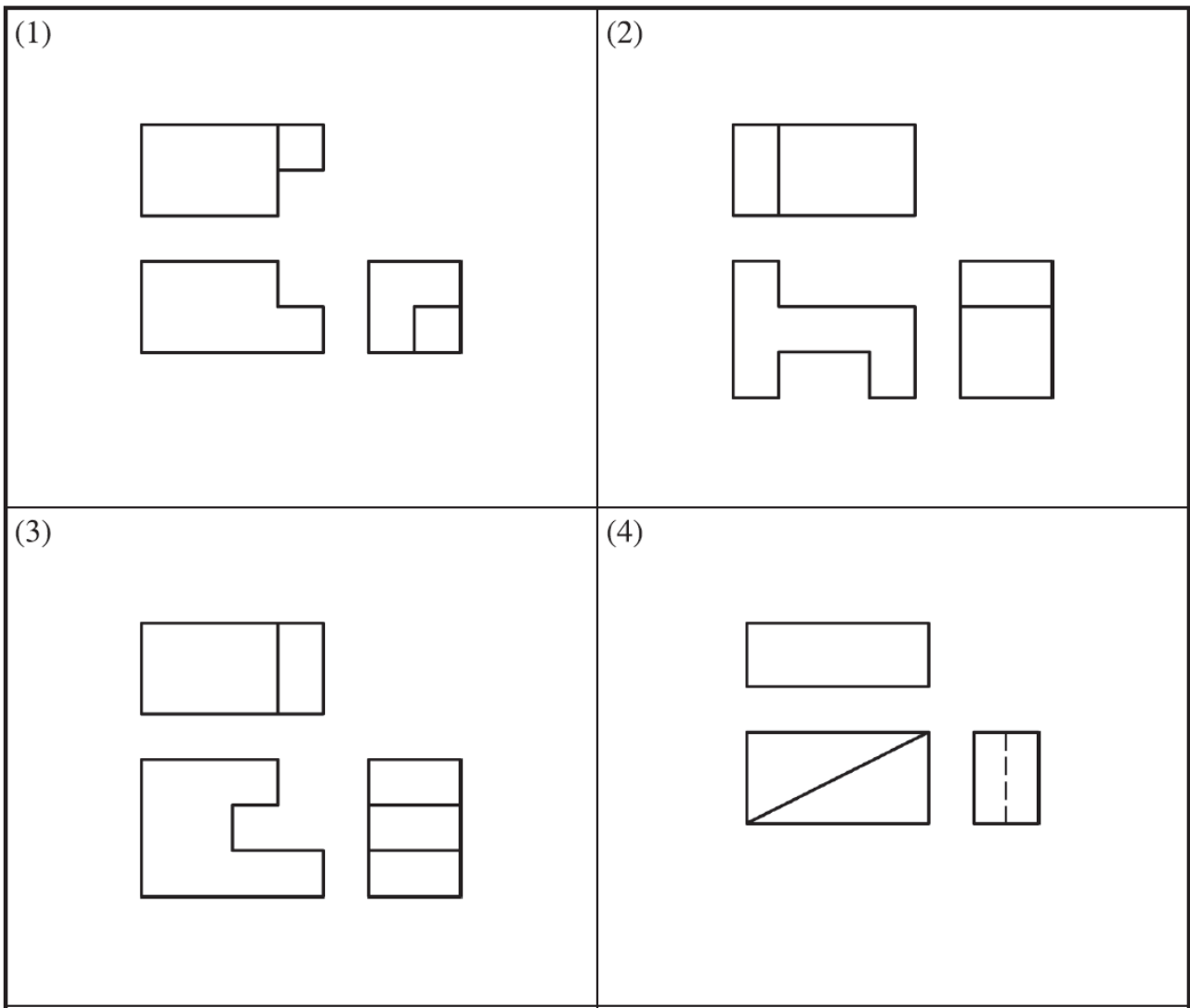

↑ 補線練習(二)

(5)

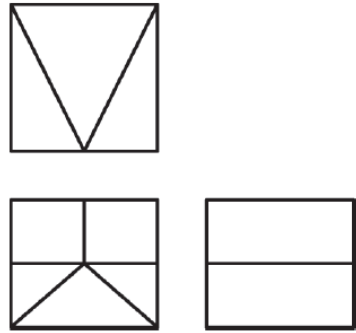

(6)

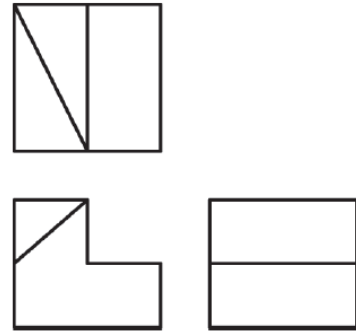

(7)

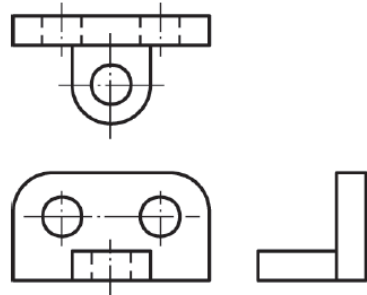

(8)

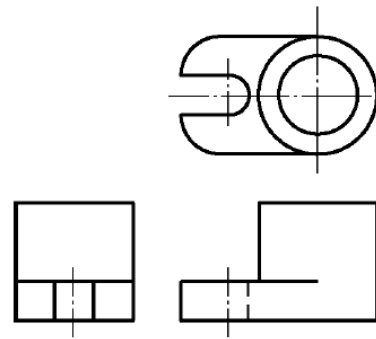

# 補圖練習

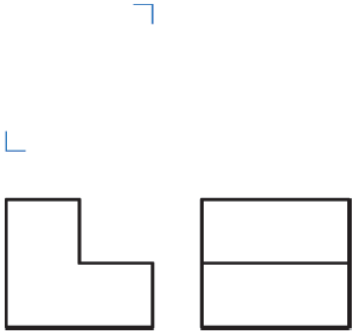
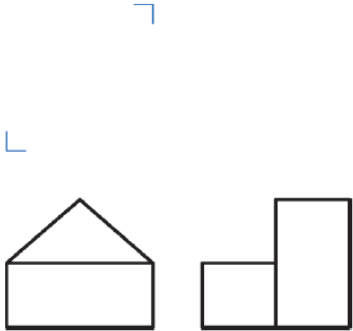
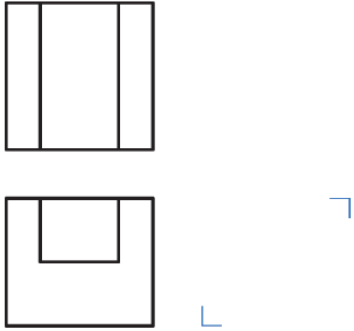
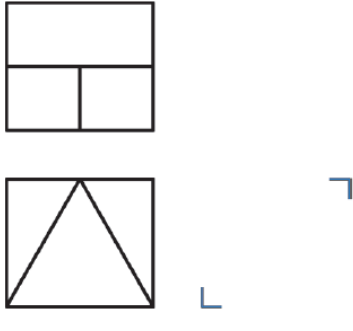
<p>(1)</p> 	<p>(2)</p> 
<p>(3)</p> 	<p>(4)</p> 

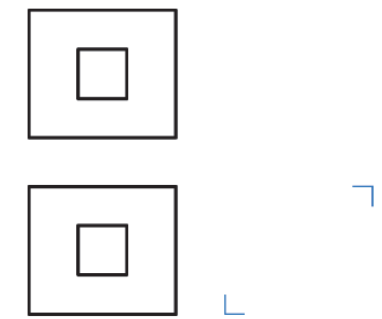
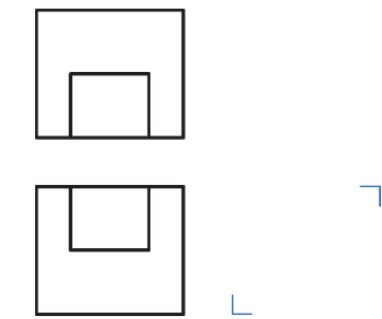
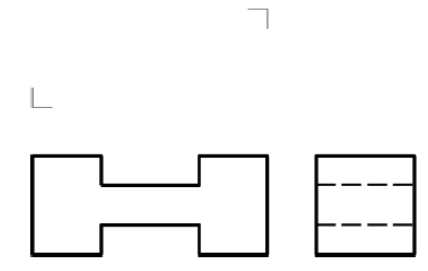
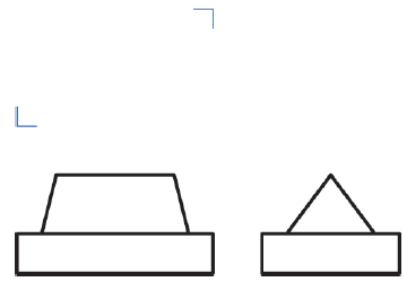
<p>(5)</p> 	<p>(6)</p> 
<p>(7)</p> 	<p>(8)</p> 

(9)

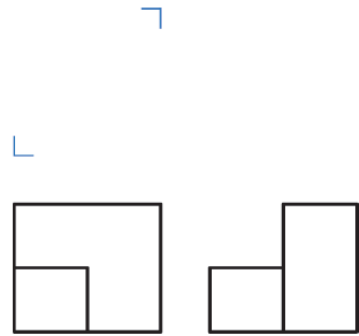

(10)

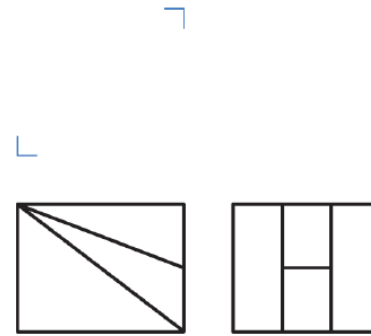

(11)

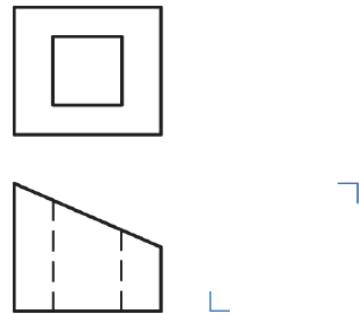

(12)

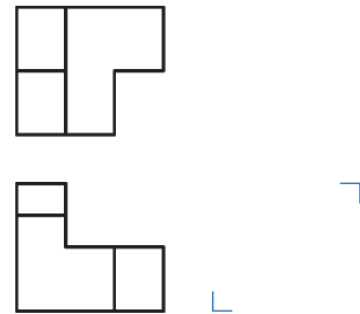

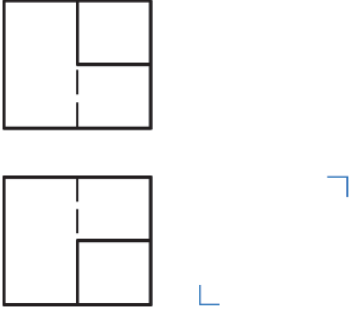
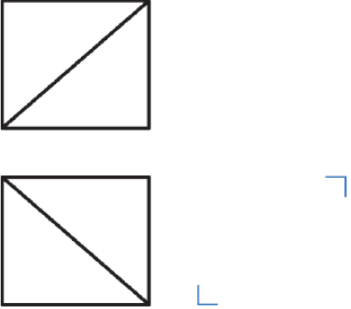
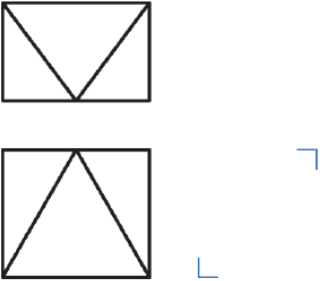
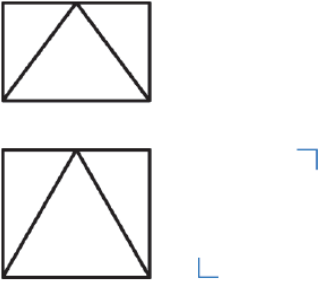
<p>(13)</p> 	<p>(14)</p> 
<p>(15)</p> 	<p>(16)</p> 



YouTube

搜尋

瀏覽

上傳

## 6 投影圖學 1

a5254805

32 部影片

訂閱

The video player displays a slide with the following content:

- 投影圖** (Projection Drawing)
- 投影法可分為中心投影法與平行投影法兩大類。
- (1) 中心投影法  
又稱為透視

The slide features a diagram illustrating central projection. It shows a viewing point (視點) at the bottom left, from which lines of sight (視線) radiate outwards. These lines pass through a transparent rectangular plane (representing the image plane) and converge on a shaded 3D object (物體) on the right. The vertices of the object are labeled A, B, C, and D, and their corresponding projections on the image plane are also labeled A, B, C, and D. A large blue play button is overlaid on the diagram.

At the bottom of the video player, the following controls are visible:

- Play/Pause button
- Volume icon
- Progress bar showing 1:13 / 9:07
- Resolution indicator: 360p
- Fullscreen, Repeat, and Shuffle icons

↑ 投影圖學 1

YouTube

搜尋

瀏覽

上傳

## 6 投影圖學 2

a5254805

32 部影片

訂閱



 投影圖學2



## 相關影片展示



↑ 透視圖學1



↑ 投影箱教學



↑ 投影圖學1



↑ 投影圖學2